



Quick Network Block

QNB-1-B

User Manual

Issue 1.13

- Battery Connection - up to 8/16 Amps of load can be delivered to the connected instruments in two separately fused banks for redundancy (8 or 16 Amp options available)
- Connect together and power up to 8 separate devices
- Data detector compatible with NMEA 0183 standard and “HS” (AIS) baud rates, and NMEA 2000 (CAN) networks

Contents

Important Notices	3
Notices	3
Foreword	3
Introduction	3
Technical features	3
Overview	4
Using QNB-1 with NMEA 0183	5
Using QNB-1 with NMEA 2000	6
Troubleshooting guide	7
Specifications	7
Company Information	8

Important Notices

Actisense and the **Actisense** logo are registered trademarks of Active Research Limited. All rights are reserved. The contents of this manual may not be transferred or copied without the expressed written permission of Active Research Limited. All other trademarks are the property of their respective owners.

The **Actisense** Quick Network Block (QNB-1) is intended for use in a marine environment, primarily for below deck use. If the unit is to be used in a more severe environment, such use may be considered misuse under the seller's warranty.

The QNB-1 has been certified to comply with the European directive for Electro-Magnetic Compatibility (EN60945), and is appropriately CE marked. Operation of the unit should be in conjunction with appropriate CE approved shielded connectors and cabling used in accordance with the CE directive EN60945. Any EMC related issues should be reported to Active Research immediately to allow the company to rectify or resolve EMC related problems in accordance with its obligations under EN60945.

If the unit is connected such that compliance failure occurs beyond the company's control, the company shall not be held responsible for compliance failure until suitable EMC guidelines for connection are seen to have been taken.

Notices

When using this document, keep the following in mind:

The products described in this manual and the specifications thereof may be changed without prior notice. To obtain up-to-date information and/or specifications, contact Active Research Limited or visit the **Actisense website** (www.actisense.com).

Active Research Limited will not be liable for infringement of copyright, industrial property right, or other rights of a third party caused by the use of information or drawings described in this manual.

Active Research Limited will not be held responsible for any damage to the user that may result from accidents or any other reasons during operation of the user's unit according to this document.

Foreword

Actisense recognises that instructions are often skipped, so we have aimed to write this document in an informative, yet direct manner that will aid the user. We have tried to cover all the points a typical user may need to know. Please read all sections before installing and using the **Actisense** QNB-1.

Full information on the complete **Actisense** product range can be found on the **Actisense website**.

Introduction

The **Actisense**(QNB-1) product was developed to ease the connection of multiple NMEA 0183 or NMEA 2000 devices to a bus, and facilitate the powering and fusing of those devices from a common point.

Technical features

Wide battery input voltage range to offer maximum compatibility, the QNB-1 can operate from a battery supply anywhere between 8 and 35 volts.

Eight x 5-way blocks of connectors, allowing up to 8 instruments to be powered and connected together at the same time.

A data LED flashes as data passes through showing that network information flowing.

Very low power consumption that is typically 10mA for the detector circuit and LEDs.

Two fuses are provided (4 amps as standard) allowing each bank to provide a total of up to 4 amps of current.

Very tough Polycarbonate case is certified to IP66 (classified as "totally protected against dust and protection against low pressure jets of water from all directions"). Being Polycarbonate, it is also incredibly strong, offering a wide temperature range and superior protection to the electronics inside.

The IP66 rating of the case is only limited by the sealing gasket strip, which can be enhanced by applying a suitable non-acid based marine sealant to the gasket after wiring and testing. This will allow use of the unit in areas where salt spray could enter, or in environments where maximum long-term reliability is paramount.

Robust Nylon grommets are certified to IP68 (classified as immersible for long periods without water ingress). Note that to achieve this level of water integrity all grommets must be occupied by round-section cables.

Large range of possible cable diameters of between 4.5 mm and 10 mm, single or multi-pair wire types can be easily accepted.

The QNB-1 does not validate or checksum the data it receives in any way. Therefore, the electronic device(s) supplying the QNB-1 with data retain(s) the sole responsibility for the data's validity.

The QNB-1 does not act as a data buffer. Its only purpose is to allow simple connections between instruments to be made reliably. If an NMEA 0183 data buffer is required, use an **Actisense** NBF-2 to boost and isolate the data from the source talker instrument to the NMEA 0183 network.

Overview

The QNB-1 circuit board appears in the figure below:

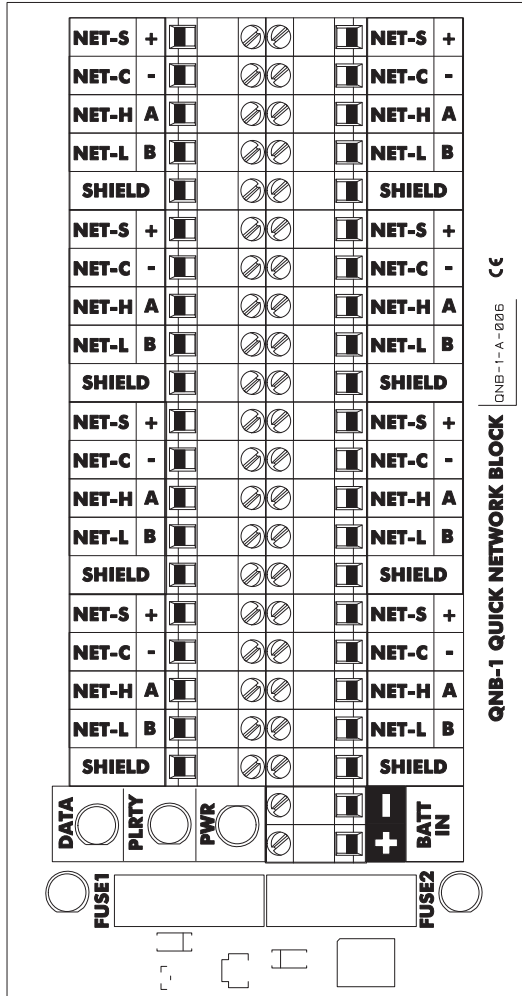

The QNB-1 has a total of 22 screw-terminal “Phoenix” type connections. These are high quality rising clamp style connectors allowing connections to be re-made many times without wear.

The board is clearly labelled with the functions of each connector and indicator. A detailed description of each label is as follows:

1. **“BATT IN”** - the battery supply input. The main boat battery is connected here, and current will flow through each fuse to each of the two banks of the QNB-1, marked **“BANK 1”** and **“BANK 2”**.

If the battery is connected in reverse by accident, then the red **“POLARITY WARNING”** LED will light, other wise the green **“PWR”** light will light. The status of each fuse can be checked at any time - the LED corresponding to that bank will be lit when power is present.

2. **“FUSE 1”** and **“FUSE 2”** are the separate fuses for each bank of four instrumnets. They are supplied as 4 amp fuses, but may be rated at up to 8 amps each for a maximum total draw of 16 amps from the battery connector.
3. Each bank of connections has 4 sets of 5 terminals, allowing connection of up to eight systems to the QNB-1.

“NET-S” is the network supply - it is connected to the battery positive terminal through the fuse corresponding to the bank number.

“NET-C” is the network common, or battery negative. All the NET-C connections are connected together.

“NET-H”, also marked **“A”** is the network data **“HIGH”** line on the NMEA 2000 network or the NMEA 0183 **“A”** line. All the NET-H connections are connected together.

“NET-L”, also marked **“B”** is the network data **“LOW”** line on the NMEA 2000 network or the NMEA 0183 **“B”** line. All the NET-L connections are connected together.

“SHIELD” is used to connect any cable shielding together - it is recommended to use shielded cable for all network connections. All the SHIELDS are connected together. The SHIELD is isolated from the ground, allowing the installer to decide whether to negative earth the shield at the QNB-1 or not.

4. The **“DATA”** LED indicates when NMEA 0183 or NMEA 2000 data is detected on the network NET-H and NET-L lines. Note that this LED flashes on the presence of data, and on NMEA 2000 networks with a low data load, it may not flash brightly, due to the very short network data packets.

To simplify explanations, the manual will have two sections, one for an NMEA 0183 connection scheme, and one for an NMEA 2000 connection scheme.

Using QNB-1 with NMEA 0183

Designed over 20 years ago, the NMEA 0183 standard has slowly become the common method by which marine electronics devices talk to one another. The standard specifies both the electrical connections that make up an NMEA system and the format of the data sentences that carry the NMEA information.

Check out the NMEA information sheet on the Actisense website for more information.

The figure below shows an example connection diagram for a QNB-1 used with an NMEA 0183 network.

Only one talker is allowed - the talker is shown powered from BANK 1 fused supply, and provides data to the network A and B lines.

Listener 1 is connected also to bank 1 power, and receives the data sent from the talker.

Listener 2 is powered from bank 2 fused supply, meaning that if a fault develops on bank 1, listener 2 can continue to operate.

Up to 5 further NMEA 0183 listeners may be connected to the QNB-1. As long as the Talker has sufficient drive capability to drive all the Listeners, then all will receive the data.

It is advised to use an oscilloscope or scope meter to verify the condition of the data signal to ensure that the minimum differential voltage signal of +/- 2v is being achieved to minimise the chance of data loss. (Note also that some NMEA 0183 listeners need more than 2 volts drive to work correctly)

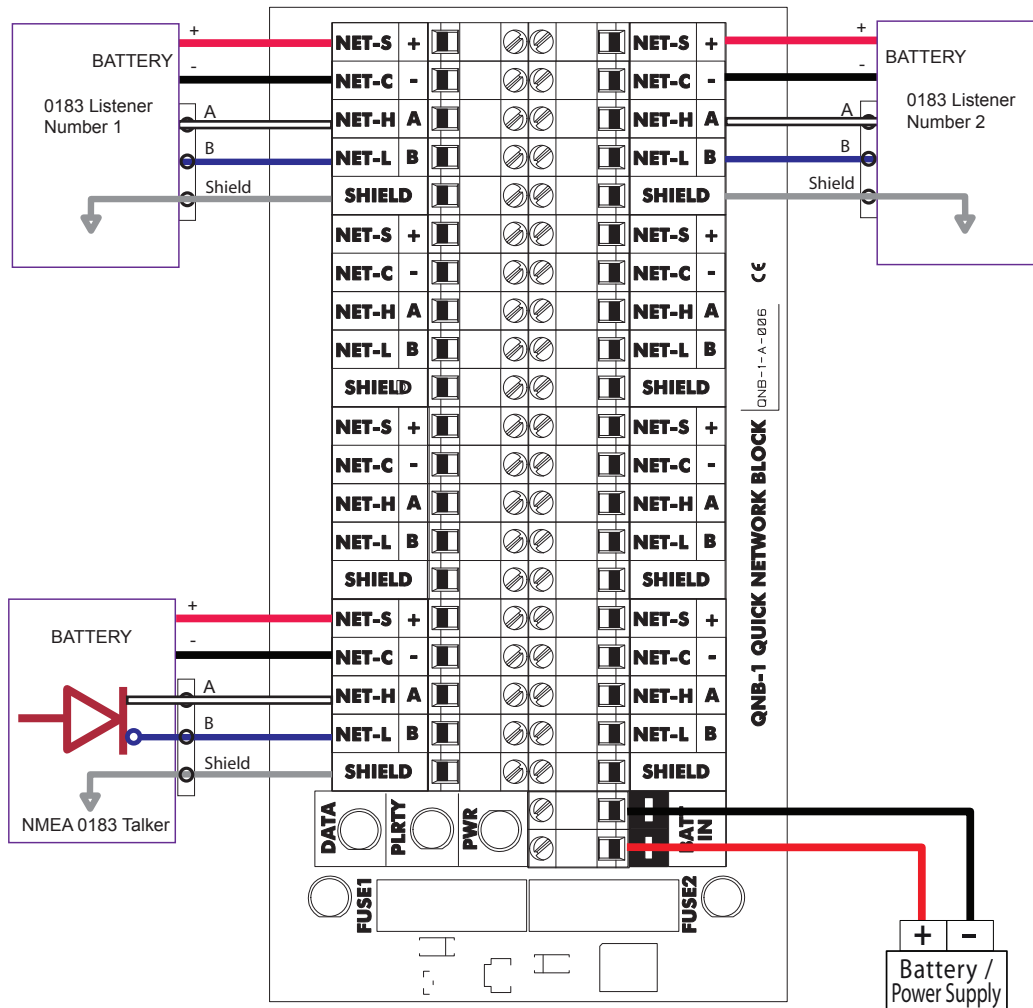

Using QNB-1 with NMEA 2000

When used on an NMEA 2000 network, the QNB-1 can connect the backbone in & out cable, and provide up to six drops for other instruments to connect directly to the backbone.

A shield connection is provided on each bank to connect the NMEA shield. This is isolated from the ground, to allow for a separate shield and ground potential to be maintained.

The diagram below shows 4 NMEA 2000 instruments connected to the QNB-1.

Instruments 1,2,3 are fully powered from the NMEA 2000 bus, whereas instrument 4 only uses the bus power to energise its NMEA 2000 interface (common in instruments such as radars etc. where a high load current is expected and thus cannot be drawn from the NMEA 2000 bus).

The in & out backbone cable is powered from the QNB-1, each branch will be thus be separately fused at 4 Amps rating. The PWR and Bank 1 & Bank 2 power LEDs show the status of the input power and the fuses.

All the data connections (NET-H and NET-L) are wired directly together, so all the data on the network can pass from the backbone to each instrument drop connection.

You can use the QNB-1 without the battery connection. Network power will flow through into the QNB-1 via the powered segment of the network, and will flow through the fuses to power the next network segment. The indicator lights will work as before. The fuses will provide downstream protection of other devices on the network. (Devices on the same bank as the input power will not be fuse protected)

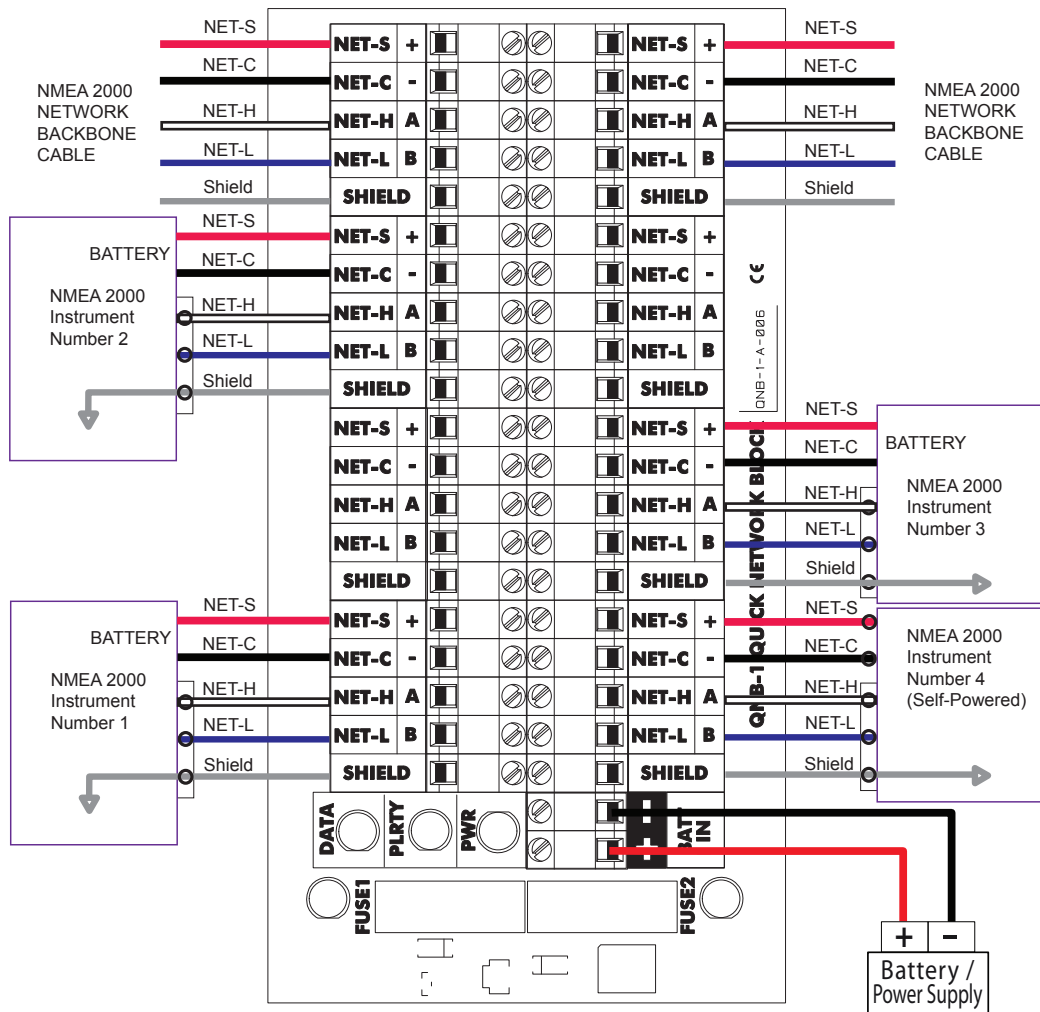

Troubleshooting guide

This guide will concentrate on all relevant troubleshooting issues above simple cable connection faults. Therefore, the cables between the QNB-1 hardware and any other devices should be checked as a matter of course, before continuing with this guide.

Problem / Error condition	Required user response
No LEDs light on the QNB-1	Measure the voltage across the battery terminals to check that the input power is applied.
The data LED does not light	Check the LED in low light conditions - the data could be brief and thus the flashes of the LED too short to see in bright light.
The Red POLARITY LED is lit	The battery supply input is reversed - swap the input battery connections.

Table 1 – Troubleshooting guide

Specifications

Parameter	Conditions / Note	Min.	Max.	Unit
Supply				
Supply voltage (note 1)		8	35	V
Supply current with no loads connected	Supply voltage = 12v		10	mA
	Supply voltage = 24v		10	mA
Other parameters				
Baud rate		4800	250	Kbit/sec
Cable diameter	Through the 8 smaller cable glands	4.5	10	mm
Cable Diameter	Through the 2 larger cable glands	6	12	mm

General				
Ambient temperature		-20	+70	°C

Table 2 – QNB-1 specifications

All specifications are taken with reference to an ambient temperature (T_A) of +25°C.

Order codes:

QNB-1	Standard QNB-1
-------	----------------

Company Information

Active Research Limited
5, Wessex Trade Centre
Ringwood Road
Poole
Dorset
UK
BH12 3PF



Telephone: 01202 746682 (International : +44 1202 746682)
Fax: 01202 746683 (International : +44 1202 746683)

Actisense on the Web: For advice, support and product details

E-mail: support@actisense.com
Website: www.actisense.com

“Actisense” is a registered trademark of Active Research Limited.